

ISO 9448-4

Material: 1.7131 - Hardness: 61-63 HRC

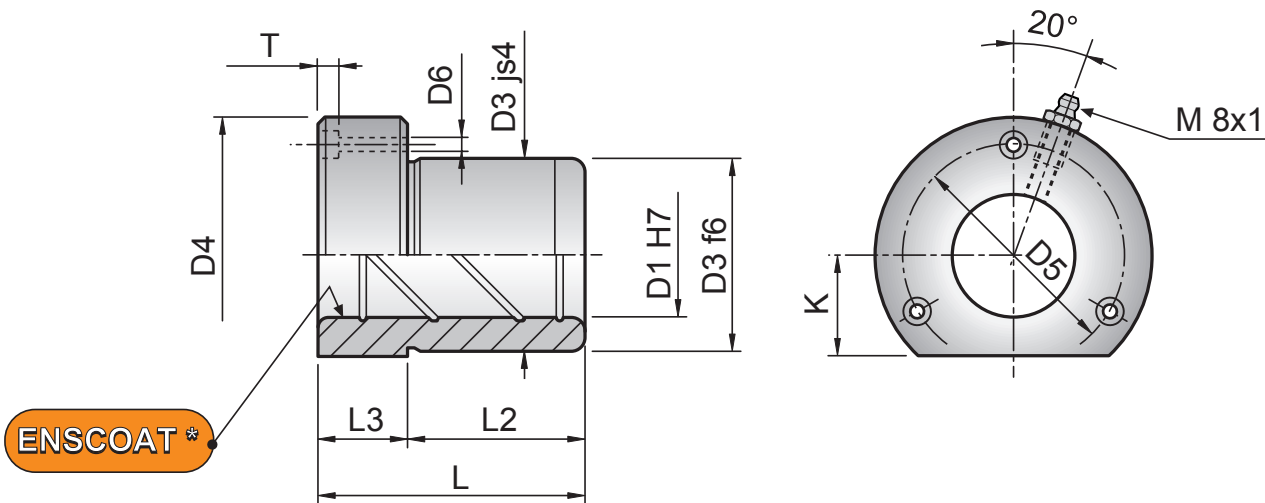

B5A-1										
Code	D1	D3	D4	D5	D6	T	K	L	L2	L3
B5A19-1	19	32	50	40	4,5	4,6	18	52	37	15
B5A20-1	20	32	50	40	4,5	4,6	18	52	37	15
B5A24-1	24	40	63	50	5,5	5,7	23	62	37	25
B5A25-1	25	40	63	50	5,5	5,7	23	62	37	25
B5A30-1	30	48	72	58	5,5	5,7	28	72	47	25
B5A32-1	32	48	72	58	5,5	5,7	28	72	47	25
B5A38-1	38	58	85	70	6,6	6,8	33	77	47	30
B5A40-1	40	58	85	70	6,6	6,8	33	77	47	30
B5A48-1	48	70	104	86	9	9	38	102	60	42
B5A50-1	50	70	104	86	9	9	38	102	60	42
B5A60-1	60	85	120	100	9	9	46	102	60	42
B5A63-1	63	85	120	100	9	9	46	102	60	42
B5A80-1	80	105	148	125	11	11	56	125	75	50

B5A-2										
Code	D1	D3	D4	D5	D6	T	K	L	L2	L3
B5A19-2	19	32	50	40	4,5	4,6	18	45	30	15
B5A20-2	20	32	50	40	4,5	4,6	18	45	30	15
B5A24-2	24	40	63	50	5,5	5,7	23	55	30	25
B5A25-2	25	40	63	50	5,5	5,7	23	55	30	25
B5A30-2	30	48	72	58	5,5	5,7	28	62	37	25
B5A32-2	32	48	72	58	5,5	5,7	28	62	37	25
B5A38-2	38	58	85	70	6,6	6,8	33	67	37	30
B5A40-2	40	58	85	70	6,6	6,8	33	67	37	30
B5A48-2	48	70	104	86	9	9	38	89	47	42
B5A50-2	50	70	104	86	9	9	38	89	47	42
B5A60-2	60	85	120	100	9	9	46	89	47	42
B5A63-2	63	85	120	100	9	9	46	89	47	42

Rivestimento ENSCOAT*

Mediante un trattamento meccanico si creano superficialmente delle microporosità che vengono riempite da polimeri fluorocarbonici. Grazie a questo processo, l'usura superficiale dei polimeri non preclude le caratteristiche del trattamento.

Buone proprietà antigrippanti, basso coefficiente di attrito (0,06) sono sviluppate grazie alla combinazione fluoropolimeri-grafite.

ENSCOAT* coating

By a mechanical treatment, superficially some micropores are forming. This microporosity is filled with fluorocarbon polymers.

Thanks to this process, the surface wear of polymers does not change characteristics of treatment.

Good anti-seized properties and low friction coefficient (0,06) are developed through the combination of fluoropolymers and graphite.

ENSCOAT*-Beschichtung

Die ENSCOAT-Beschichtung ist eine Oberflächenbeschichtung auf Basis von Fluoropolymeren, die auf die Oberfläche der Führungsbuchse aufgetragen wird und in die äußere Schicht des Materials eindringt. Da diese Beschichtung in die Poren des Materials eindringt, gehen auch bei verschleißten Teilen die Gleiteigenschaften nicht verloren. Dank der Kombination Fluoropolymere-Grafit verbindet die ENSCOAT-Beschichtung gute selbstschmierende Eigenschaften und einen niedrigen Reibungskoeffizienten (0,06).

B5A-4										
Code	D1	D3	D4	D5	D6	T	K	L	L2	L3
B5A19-4	19	32	50	40	4,5	4,6	18	38	23	15
B5A20-4	20	32	50	40	4,5	4,6	18	38	23	15
B5A24-4	24	40	63	50	5,5	5,7	23	38	23	15
B5A25-4	25	40	63	50	5,5	5,7	23	38	23	15
B5A30-4	30	48	72	58	5,5	5,7	28	45	30	15
B5A32-4	32	48	72	58	5,5	5,7	28	45	30	15
B5A38-4	38	58	85	70	6,6	6,8	33	55	30	25
B5A40-4	40	58	85	70	6,6	6,8	33	55	30	25
B5A48-4	48	70	104	86	9	9	38	62	37	25
B5A50-4	50	70	104	86	9	9	38	62	37	25